

AE-DS45B & AE-DS52B Countertop Reversible Sheeters

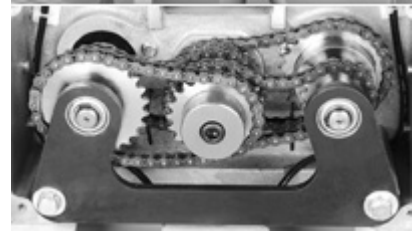

Perfectly stretched and sheeted products every time!

- Croissants
- Pastry Puffs
- Danish rolls
- Cookie dough
- Pizza dough
- Pie crusts



Permanently lubricated, heavy-duty alloy steel gears for years of worry-free use

Let us help with your baking operation's efficiency!

- Saves time and labor, no extensive training required
- Make wrinkle-free sheets of product ready for cutting or topping
- Allows you to focus on important things like your recipe & sales
- Produce a wide variety of products with adjustable thickness
- Unbeatable value pricing. Contact an AE representative today!



Standard Features

- Handle adjusts thickness for a variety of needs. Convenient reverse/forward switch
- Durable, heat treated alloy steel belt and chain drive
- Convenient fold-up design suitable for countertops
- Powerful motor with totally enclosed, permanently lubricated bearings
- Heavy-duty safety guard encloses moving rollers
- Conforms to the highest food sanitation standards. CE Approval
- Frame and housing construction from quality polished aluminum alloy and stainless steel
- Sanitary, heavy-duty PVC fiber conveyor belt with precise, tear-free rollers.

Standard Warranty

- 1 year parts and ninety days labor
- Must register with American Eagle

Specifications Summary (See reverse for details)

Model	Motor	Voltage	Roller Size Diameter x L	Overall Dimensions W x L x H	Maximum Dough Batch	Adjustable Thickness	Working Surface W x L	Ship Weight (Lbs)
AE-DS45B	½ H.P.	220V/60Hz/1Ph	3.5" x 17.7"	32" x 70" x 24"	11 Pounds	0.0"-1.18"	16.9" x 66.9"	305 (258 net)
AE-DS52B	½ H.P.	220V/60Hz/1Ph	3.5" x 20.5"	35" x 82" x 24"	11 Pounds	0.0"-1.57"	19.7" x 78.7"	321 (271 net)

Contact an American Eagle representative today to find the right sized sheeter for your bakery's volume!

American Eagle: Value, Quality, and Reliability

AE-DS45B & AE-DS52B Countertop Dough Sheeters

Specifications

Due to continuous product improvement, specifications may change without notice

<p>Motor: ½ HP & 4 Amps. Motor overload protection w/ reset button. Totally enclosed to prevent oil leaks or food contamination.</p> <p>Transmission: Easy-to-maintain gear belt and chain system. Transmission is completely enclosed and permanently lubricated for years worry-free operation.</p> <p>Electrical: 220V /60 Hz /1Ph 6 foot long cord with three wire ending. Installation must be made by qualified electrician in accordance with all applicable laws & codes.</p> <p>On/Off Switch: Easy to find red and green buttons located on front of machine. Switch controls forward and reverse direction.</p> <p>Construction: Heavy-duty polished aluminum alloy housing. Stainless steel and PVC fiber conveyer belt meets industry sanitation demands.</p> <p>Enamel Finish: Powder white paint. Heat treated to resist rust, scratches, and dents.</p>	<p>Safety Guard Prevents operator contact with moving rollers. Machine will automatically shuts off if safety cover is removed.</p> <p>Capacity: 11 (5 Kg) of dough per batch can be rolled onto the conveyer belt. Max sheet width determined by roller length. Max sheet length determined by belt surface.</p> <table border="1"> <thead> <tr> <th></th> <th>Width</th> <th>Length</th> </tr> </thead> <tbody> <tr> <td>AE-DS45B</td> <td>43 cm 16.93 in</td> <td>170 cm 66.93 in</td> </tr> <tr> <td>AE-DS52B</td> <td>50 cm 19.69 in</td> <td>200 cm 78.74 in</td> </tr> </tbody> </table> <p>Belt moves approximately 3 cm/sec.</p> <p>Adjustable Thickness Side handle quickly adjusts to the precise thickness you require. Handle operates between 0in (1 mm) and 1.18" (30 mm-DS45B) or 1.57" (40mm-DS52B)</p> <p>Stored Dimensions AE-DS45B Stored Position: 25.88"W x 27.5"H (66cm x 70cm) AE-DS52B Stored Position: 28.43"W x 33.33"H (72.5cm x 85cm)</p>		Width	Length	AE-DS45B	43 cm 16.93 in	170 cm 66.93 in	AE-DS52B	50 cm 19.69 in	200 cm 78.74 in	<p>Shipping Information Freight Class: 85 Crates are affixed to a skid (pallet). The weight and dimensions of this skid are included below and may vary from shipment to shipment.</p> <p>AE-DS45B Dimensions Net Weight: 258 lbs (117 kgs.) Ship Weight: 305.8 lbs (139 kgs.) Packing Crate: 32.2" x 29.2" x 35.7" (82 cm x 74.5 cm x 91.0 cm)</p> <p>Machine: Overall Width = 32.28" (82 cm) Overall Length= 69.69" (177 cm) Overall Height= 24.41" (62 cm)</p> <p>AE-DS52B Dimensions Net Weight: 271 lbs. (123 kgs.) Ship Weight: 321.2 lbs (146 kgs.) Packing Crate: 36.5" x 29.8" x 38" (93 cm x 76 cm x 97 cm)</p> <p>Machine : Overall Width = 35.29" (90 cm) Overall Length = 81.89" (208 cm) Overall Height = 24.41" (62 cm)</p>
	Width	Length									
AE-DS45B	43 cm 16.93 in	170 cm 66.93 in									
AE-DS52B	50 cm 19.69 in	200 cm 78.74 in									

Dimensions

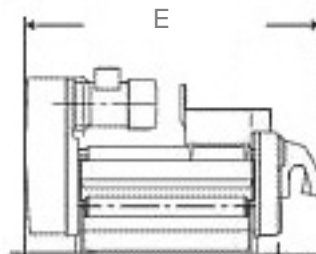
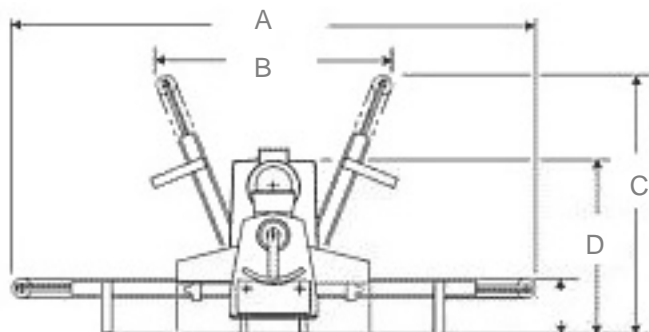

AE-DS45B		
	in	cm
A	69.69	177
B	25.88	66
C	27.45	70
D	24.41	62
E	32.28	82

AE-DS52B		
	in	cm
A	81.89	208
B	28.43	72.5
C	33.33	85
D	24.41	62
E	35.29	90